



New technologies and strategies for fuel cells and Hydrogen Technologies in the phase of recycling and dismantling

Grant No. 700190

WP2 Regulatory analysis, critical materials and components identification and mapping of recycling technologies

D2.3 Regulatory framework analysis and barriers identification

Status: F

(D: Draft, FD: Final Draft, F: Final)

Dissemination level: PU

(PU: Public, CO: Confidential, only for members of the consortium (including the Commission Services))



This project has received funding from the Fuel Cells and Hydrogen 2 Joint Undertaking under grant agreement No 700190. This Joint Undertaking (JU) receives support from the European Union's Horizon 2020 research and innovation programme and Spain, Italy, Slovenia.

The contents of this document are provided "AS IS". It reflects only the authors' view and the JU is not responsible for any use that may be made of the information it contains.

Document Change Control

Version Number	Date of issue	Author(s)	Brief description of changes
V01	8.05.2017	Sabina Fiorot, EP	First draft document. Waiting for additional comments by partners.
	19.05.2017	Diego Iribarren, IMDEA	Comments and corrections
V02	23.05.2017	Sabina Fiorot	revisions
V03	25.05.2017	Lorenzo Castrillo, FHA	Comments, corrections inputs
V04	06.06.2017	Sabina Fiorot, EP	Final draft version
	12/06/2017	IQMT _Ana Ferriz (FHA)	Evaluation of deliverable and comments
V05	12/06/2017	Sabina Fiorot, EP	Final version
	26/06/2017	IQMT _IMDEA	Evaluation of deliverable and comments
V06	27/06/2017	Sabina Fiorot, EP	Final version after IQMT and to submit on EU portal

Executive Summary

The development of FCH technologies is nowadays widely extended and well-known all over the world. From its very beginning, several applications have been the ones that have had the most important growth, thus, nowadays: there are more than 540 FCEV already running, 120 000 micro CHP stationary fuel cells only in Japan and more than 80 HRS worldwide.

The first commercialization phase has already been proved and FCH technologies are currently overcoming the so-called Valley of Death in order to become a fact in all the sectors related to the electricity or fuel consumption. Fuel cells are environmentally and economically advantageous. They provide an immediate path to lower GHG and air pollution emissions through increased energy efficiency, and this, in turn, leads to unique and substantial benefits for our planet, our personal health and our economy.

There are still many barriers to the deployment of fuel cells, mainly related to the costs of the materials, assembly, reliability and durability of the system, sensitivity of end users, lack of distribution and infrastructures and, no less important, the lack of specific regulations in the process of design, material selection and end of life cycle of fuel cell systems.

The present document analyses more in details the main Directives to EU and Member States to evaluate the requirements and limitations that FCH technologies have to accomplish during their whole life cycle phases including selection and use of raw materials, manufacturing, transport and distribution, use and end of life. Emphasis is given to end of life, including recycling and dismantling regulations and policies.

This assessment has provided a list of barriers for the deployment of FCH technologies in what regards to recycling and dismantling.

Contents

1. Introduction	10
1.1 Study background	10
1.2 Methodology in the study	10
1.3 FCH system design.....	10
1.4 Material selection, design and end of life management of FCHs	14
2. Legislation analysis.....	15
2.1 Legislation on material selections and design	15
2.2 Legislation on end of life.	16
2.2.1 End of life of balance of plant components in FCHs	21
2.2.2 Electronic parts in FCHs as waste electrical & electronic equipment (WEEE)	21
2.2.3 Hydrogen FCEV (Fuel cell vehicles) on end of life vehicles.....	25
2.2.4 Batteries in a FCH system end of life.....	29
3. Barriers for deployment of FCH technologies: regulatory barriers analysis	<u>3332</u>
3.1 Lack of specific legislations on FCH systems	<u>3332</u>
3.2 Hazardous materials in FCH technologies and barriers on REACH Regulation	<u>3433</u>
3.3 Barriers related to critical raw materials (connected with the Eco-Design Directive)	<u>3534</u>
3.4 Barriers on Hazardous waste and landfill Directives.....	<u>3635</u>
3.5 Barriers on WEEE and RoHS Directives	<u>3736</u>
3.6 Barriers on End-of-life Vehicles	<u>3736</u>
3.7 Barriers on Eco-design Directives.....	<u>3837</u>
4. Conclusions	<u>3837</u>
5. References	<u>4039</u>

List of Figures

Figure 1 – Schematic representation of a FC system and its components (3).....	11
Figure 2 –FC system and its components	13
Figure 3 –FC system cabinet and BoP allocation	13
Figure 4 –Stages identified within end of life (4).	14
Figure 5 – Legislation reference to life cycle of a FCH system.	15
Figure 6 –Electrical components in a fuel cell system	21
Figure 7 – Directives on WEEE from 2002 to 2018 (18).....	22
Figure 8 – Determination of hazardous or not-hazardous waste (64).....	<u>3635</u>

List of Tables

Table 1 – Main components and material of BoP (2) and the related EU Directives.	19
Table 2 – Main components and material of stacks (2) and the related EU Directives	20
Table 3 – maximum tolerated concentration value (20)	22
Table 4 – Member states transposition of the Directive 2000/53/EC	24
Table 5 – FCEV penetration in Europe in different time horizons and scenarios	25
Table 6 – ELV directive in various countries	27
Table 7 – Member states transposition of the Directive 2000/53/EC	28
Table 8 – Raw material demand for electric vehicles	29 28
Table 9 – Member states transposition of the Directive	31

Abbreviations

AC	Alternate Current
ASR	Automotive Shredder Residue
AWE	Alkaline Water Electrolyser
BoP	Balance of Plant
CHP	Combined Heat and Power
CRM	Critical Raw Material
DC	Direct Current
EC	European Commission
EEE	Electrical Electronic Equipment
ELV	End of Life Vehicles
EoL	End of Life
EPR	Extended Producer Responsibility
EU	European Union
FC	Fuel Cell
FCEV	Fuel Cell Electric Vehicles
FCH	Fuel Cell and Hydrogen
GHG	Green House Gas
HRS	Hydrogen Refuelling Station
HTPEM	High Temperature PEM fuel cell
ICE	Internal Combustion Engine
LCA	Life Cycle Analysis
MEA	Membrane Electrode Assembly
PCB	Printed Circuit Board
PEM	Polymer Electrolyte Membrane
PEMEC	Polymer Electrolyte Membrane Electrolyser Cell
PEMFC	Polymer Electrolyte Membrane Fuel Cell
PEMWE	Polymer Electrolyte Membrane Water Electrolyser
PGM	Platinum Group Metals
PV	Photovoltaic panel
REACH	Registration, Evaluation, Authorisation and Restriction of Chemicals
REE	Rare Earth Elements
RoHS	Restriction use of Hazardous Substances
SVHC	Substance of Very High Concern
SOFC	Solid Oxide Fuel Cell
WEEE	Waste Electrical Electronic Equipment
WFD	Waste Framework Directive

Short list of EU legislation

Legislative act	Short name
Directive 2006/66/EC of the European Parliament and of the Council of 6 September 2006 on batteries and accumulators and waste batteries and accumulators and repealing Directive 91/157/EEC.	Batteries Directive
Directive 2009/125/EC of the European Parliament and of the Council of 21 October 2009 establishing a framework for the setting of Eco Design requirements for energy-related products.	Eco Design Directive
Directive 2000/53/EC of the European Parliament and of the Council of 18 September 2000 on end-of life vehicles.	ELV Directive
Council Directive 1999/31/EC of 26 April 1999 on the landfill of waste.	Landfill Directive
Directive 2004/12/EC of the European Parliament and of the Council of 11 February 2004 amending Directive 94/62/EC on packaging and packaging waste	Packaging Directive
Regulation (EC) n° 1907/2006, of 18 December 2006 concerning the Registration, Evaluation, Authorisation and Restriction of Chemicals (REACH), establishing a European Chemicals Agency, amending Directive 1999/45/EC and repealing Council Regulation (EEC) No 793/93 and Commission Regulation (EC) No 1488/94 as well as Council Directive 76/769/EEC and Commission Directives 91/155/EEC, 93/67/EEC, 93/105/EC and 2000/21/EC, Regulation (EC) n° 1907/2006.	REACH
Directive 2011/65/EU of the European Parliament and of the Council of 8 June 2011 on the restriction of the use of certain hazardous substances in electrical and electronic equipment (recast version).	RoHS II Directive
Directive 2008/98/EC of the European Parliament and of the Council of 19 November 2008 on waste and repealing certain Directives	Waste Directive Framework Waste
Directive 2012/19/EU of the European Parliament and of the Council of 4 July 2012 on waste electrical and electronic equipment (WEEE) (recast).	WEEE Directive
Council Directive 91/689/EEC of 12 December 1991 on hazardous waste	Hazardous Waste Directive

1. Introduction

1.1 Study background

High deployment of FCH technologies is expected in the near future in the EU to decarbonize energy and transport sectors. However, commercialization of FCH technologies (mainly PEM and alkaline electrolyzers as well as PEM and Solid Oxide fuel cells) is not prepared for full deployment mainly concerning recycling and dismantling stage. The main goal of the project is delivering the reference documentation and studies about existing and new recycling and dismantling technologies and strategies applied to FCH technologies. One of the key steps for the commercialization and market massive introduction of the technologies is a specific legislation regarding end of life and recycling of each fuel cell system component. In this report compliance with environmental standards mainly focused in the end of life of the technologies will be studied analysing existing EU and national legislative framework.

1.2 Methodology in the study

The first main approach in the study was the use of two previous deliverables - *D 2.1 Assessment of critical materials and components in FCH technologies* (1) and *D 2.2 Report on existing recycling technologies applicable to FCH products* (2). In those reports, critical materials and the main end-of-life existing strategies for FCH products have been identified. Then, the overall FCH system design is described so as to define each subsystem. Finally, current regulations at EU and Member states level and regulations related to the FCH systems mainly used and close to the market as vehicles, CHP and backup systems were collected for each subsystem previously identified.

(The main approach for developing the study was starting from the two deliverables, ones *D 2.1 Assessment of critical materials and components in FCH technologies* (1) and *D 2.2 Report on existing recycling technologies applicable to FCH products* (2) that have identified the critical materials and mainly the end of life existing strategies for FCH products. The second approach was identifying the overall FCH system design and for each subsystem collecting current regulations at EU level and Member states and regulations related to the FCH systems mainly used and close to the market as vehicles, CHP and backup systems.)

Regulations about disposal of waste inside the Europe member states change from country to country, but the EC issued some directives to standardize disposal, recycle and reuse of waste and their accessories and materials.

HYTECHCYCLING Project aims to propose a collection of European directives to regularize the correct end of life cycle of FCH system. Inside this report such directives and the main points of interest that relate to the FCH technologies will be collected.

The collection presented here is an extrapolation of what is shown on the directives as in any of them there is a relation on fuel cell hydrogen systems.

1.3 FCH system design

The overall FCH system design is the integration of subsystems that require the integration and assembly of other components.

The fuel cell subsystem consists of a:

- FCH stack

- FCH BoPs which include all the peripheral components linked with the fuel cell subsystem, including controls (air blower, humidifier, water cooling pump, heat exchanger, valves, hydrogen recirculation pump).

The stack is integrated with the BoP components.

The power electronics and conditioning subsystems include all of the components required for power regulation and system control, including voltage regulation, overall system control and batteries (if grid-independent operation is being analysed).

In addition, common to each subsystem are piping, valve connections and insulation for high temperature reactors. All these elements can be identified at [Figure 1](#) ~~Figure 4~~.

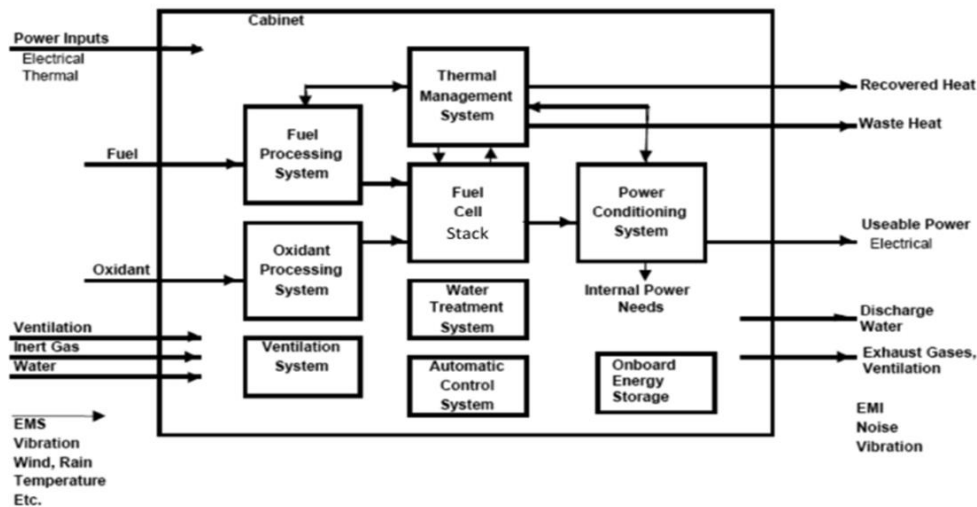

Figure 1 – Schematic representation of a FC system and its components (3).

Fuel cells considered in the project are PEMFC and SOFC (3). For the purpose of the LCA studies and identification of the critical materials of PEMFC and SOFC, two modules or boundary conditions have been identified:

- FC stack,
- FC system.

The FC stack consists of individual cells that are combined in a modular format by electrically connecting the cells to form units with the desired output capacity.

The FC single cell main components are:

- Contact layer,
- Cathode gas distribution layer,
- Electrolyte (in matrix),
- Anode gas distribution layer,
- Catalyst layer,
- Contact layer.

The FC stack main components are:

- Interconnect (also called bipolar or flow-field plate),
- Seal gasket,
- Current collector,
- A number of individual cells.

The FCH System as a whole comprises of the stack together with BoP components (all other blocks alongside the FC stack in [Figure 1](#)~~Figure 4~~). The cell stack is terminated by the manifold plate which connects the stack to the BoP. The BoP supplies fuel and air, ensures constant stack temperatures, manages required gas/fluid recycling, and provides infrastructure for start-up and shut-down as well as ancillary systems for total system control and power conditioning. The precise arrangement of the BoP largely depends on the fuel cell type, the fuel choice, and the end use of the system. Specific operating conditions and requirements of individual FC and FC stack designs also determine the characteristics of the BoP. BoP can be classified as the equipment necessary for the operation of the FC (essential BoP, ancillary BoP).

The BoP supports all system operating modes such as cold start, cool-down to ambient temperature, standby, power-up from standby, cool-down to standby, load following and emergency shut-down:

- Air management (blower, compressor, metering, piping humidification, pre- heat),
- Fuel management (fuel pump/blower, metering, fuel cleaning, fuel processing, humidification, cooling/pre-heat),
- Thermal management system – air or water cooled (heat exchangers, after/start-up burner, steam generator),
- Recycle streams (water, fuel, CO₂, liquid electrolyte).

Most balance of plant materials fall into the following categories: structural plastics, elastomers, coolants, assembly aids and metals.

Ancillary BoP supports power management and system control, electric system components:

- Power conditioning (DC-DC, DC-AC inversion),
- Control system and instrumentation (sensor, hardware, software).

External BoP is a specific application and maximizes energy efficiency:

- Housing/pressure vessels,
- Waste heat recovery.

All the systems are enclosed in a cabinet generally made of metals (aluminium, steel, etc.).

The two Figures below report a configuration of a FCH system, the main BoP components and the cabinet.

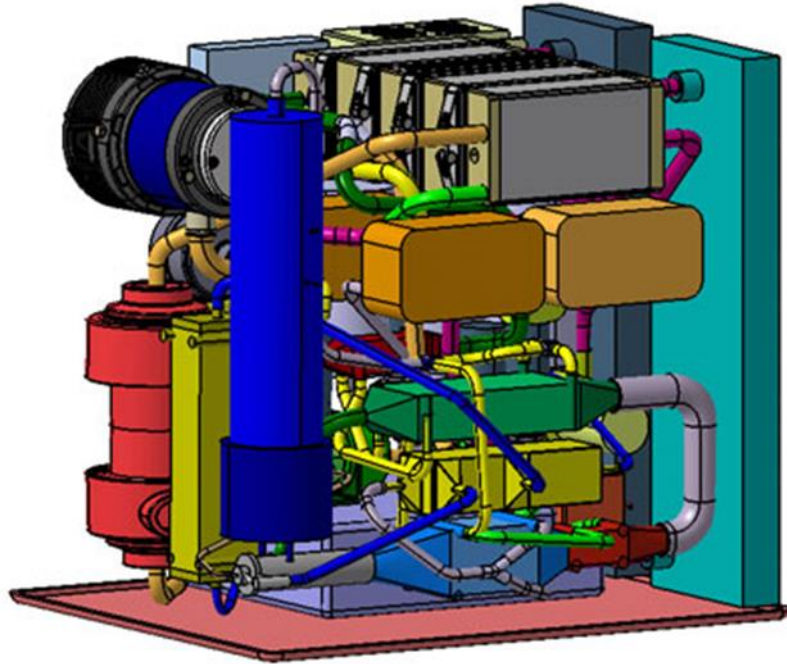

Figure 2 –FC system and its components



Figure 3 –FC system cabinet and BoP allocation

1.4 Material selection, design and end of life management of FCHs

FCH system's life include different stages that must be considered and understood so as to identify better the main regulation comply with the FCHs. The following figure reports a simple scheme of a fuel cell life cycle from its production until its disposal.

Prior to identify the main regulations comply with the FCHs, it is important to understand the whole life of FCH system (1). The following figure reports a simple scheme of a fuel cell life cycle:

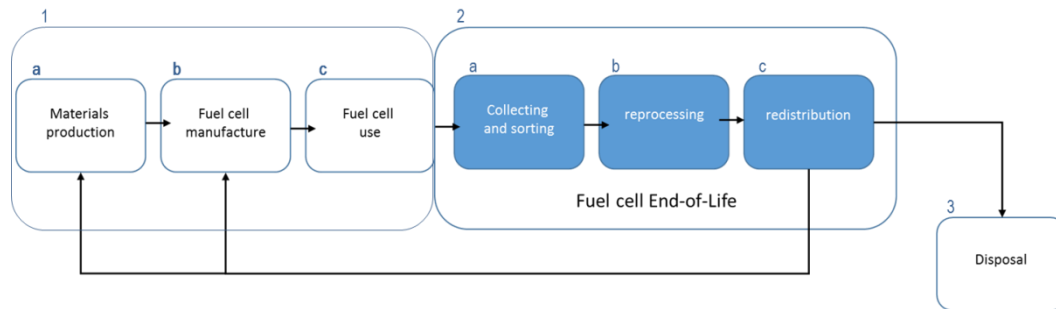

Figure 4 –Stages identified within end of life (4).

1. The first three steps are related to the fuel cell life, and they consist on:
 - a. Material production and selection: in which the fuel cell and BoP materials are selected.
 - b. Design phase of the fuel cell: manufacture and construction after the material production.
 - c. Finally, the usage phase of a fuel cell or a FCH system.
2. The following three steps are related to the end of life of a fuel cell. Following the EoL scheme it is possible to merge it into three steps:
 - a. Collecting and sorting: end-of-life products must be collected following disposal by the consumer and after sorted;
 - b. Reprocessing operation: according to general waste management principles, reprocessing may involve the reuse of components (either directly or following some remanufacture/repair operation) and/or the recycling of materials contained within the product.
 - c. Finally, the useful components and materials are redistributed to an end user, either in a closed loop (material from a product system is recycled in the same product system) or open loop (material from one product system is recycled in a different product system) scenario.
3. In the event of some material being unsuitable for redistribution, this portion of the end-of-life product will be disposed.

The Figure 5 below reports Legislation reference to life cycle of a FCH system.

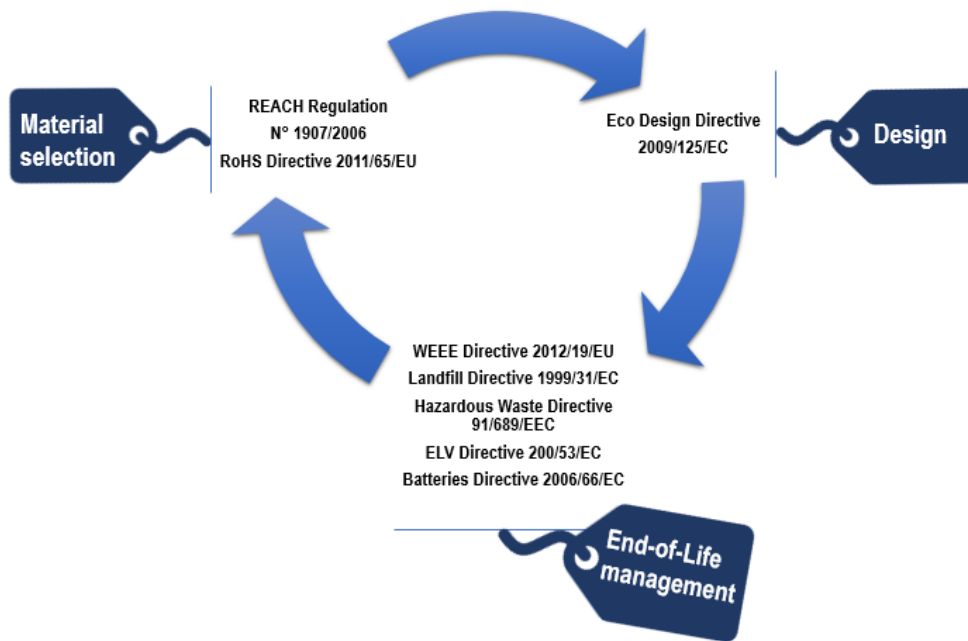

Figure 5 – Legislation reference to life cycle of a FCH system.

2. Legislation analysis

This chapter reports the main legislations classified following the scheme reported above as: material selection & design, and end of life legislations.

2.1 Legislation on material selections and design

Two main legislations are related to the material selection and design of the system, they are about the product life cycle. These two legislation acts are REACH (5) and Eco-design (6).

REACH is the European Regulation on Registration, Evaluation, Authorisation and Restriction of Chemicals. It entered into force in 2007, replacing the former legislative framework for chemicals in the EU.

REACH shifts the responsibility from public authorities to industry with regards to assessing and managing the risks posed by chemicals and providing appropriate safety information for their users. It impacts on a wide range of companies across many sectors beyond the chemical industry. It requires new forms of cooperation among companies, enhancing communication along the supply chain, as well as developing tools to guide and assist companies and public authorities for its implementation.

REACH was adopted in December 2006 and entered in force in 2007 (5). The implementation period for all the Member states was between 2007 and 2018. The Annex XVII of the REACH Regulation includes substances restricted for which manufacture, placing on the market or use is limited or banned. The REACH reports also information on SHVC (Substance of Very High Concern). Nickel or its compounds are present in the documents.

The FCH system must be produced in the respect of Eco-design and the parameters established by the EC (6).

An eco- and initial design of the product is one of the keys in order to better repair or recycle a product and so reuse the main components. Following the new objectives towards a Circular Economy, a new Eco-design Working Plan 2016-2019 was adopted (9).

The Plan has the objective to follow a requirement design in order to have easier and safer dismantling of it. The draft Regulation (10) also requires manufacturers to increase recycling, for example avoidance of welding or gluing of certain components (e.g. printed circuit boards, capacitors, batteries and internal power supplies), identifying plastic parts and the presence of cadmium and mercury.

Some indications are asked manufacturers in order to reach the recycling targets on the new Directives.

Another specific Directive on restriction material use is on Electrical and Electronic Equipment (RoHS, restriction of hazardous substances directive) (7) mainly linked with the WEEE Directive (Waste Electrical and Electronic Equipment) (8). They will be treated more in details in later chapters.

2.2 Legislation on end of life.

The body of legislation associated with end-of-life management covers a broad range of requirements. In the product life cycle and in its end of life, the waste management legislation is of high importance. One of the main points of waste legislation is related to the identification and classification of waste as hazardous or non-hazardous and the classification that affects the transportation (both domestic and international), storage and treatment of waste.

FCH systems at end-of-life fit the WFD (Waste Framework Directive 2008/98/EC on waste) (11).

One of the main points of the EoL management of the systems and products is related to the principle of EPR (Extended Producer Responsibility) reported in the Article 8 of the WFD. EPR is “an environmental policy approach in which a producer’s responsibility for a product is extended to the post-consumer stage of a product’s life cycle”. In practice, EPR implies that producers take over the responsibility for collecting or taking back used goods and for sorting and treating for their eventual recycling.

The directive specifies how the waste has to be treated within the EU. The primary objective of the directive is to protect the environment and human health through the prevention of hazardous and negative effects deriving from waste generation and management. According to the directive, better protection of the environment requires a series of measures applicable in order of priority:

- 1) prevention of rejection;
- 2) preparation for the reuse;
- 3) recycling;
- 4) other recovery (e.g. energy);
- 5) disposal.

This means that first you have to think about preventing rejection while avoiding producing it; if this is not possible, taking measures to use it again, in order to recycle etc.

Each Member State of the EU can implement further legislative measures to strengthen this hierarchy, but the important thing is always guaranteeing human health and the respect of the environment. Anyone who produces or holds a waste is obliged to provide for its processing, or must hand it over to someone else in charge to do it. In particular, the storage and treatment of hazardous waste must follow a code even more

severe than household waste disposal to avoid any risk to humans or to environment. Since also that waste generation tends to increase in Europe, the legislation calls for strengthening measures for the prevention and related impacts reduction and encouraging the recovery of waste.

WFD has been adopted by the Council on 20 December 2008, and published in the Official Journal of the European Union on 22 November 2008. It entered into force on 12 December 2008. Deadline for the transposition of the revised Waste Framework Directive into national legislation of the Member States passed on 12 December 2010 (11).

The main implementation timelines of the Directive are reported:

- By 12 December 2013, Member States to have established waste prevention programmes.
- By the end of 2014, Commission to review recycling targets and measures set under Article 11 and (potentially) set waste prevention and decoupling objectives for 2020.
- By 2015, all Member States to have implemented separate collection for minimum of paper, metal, plastic and glass.
- By 12 December 2016, Member States to review waste management plans created under Article 28.
- By 12 December 2019, Member States to review waste prevention programmes established under Article 29.
- By 2020, Member states have to get recycling targets of: 50% by weight of household waste (including paper, plastic, metal and glass) 70% by weight of non-hazardous construction and demolition waste (12).

In December 2015, the EU Commission adopted a new economic model to support the transition to a Circular Economy in Europe, including waste legislative proposals with the aim to reduce landfilling and increase recycling and reuse procedures. The Circular Economy, formally called “Towards a circular economy: A zero waste programme for Europe”, wants to joint together all the waste directives. The Action Plan has to reduce the waste mainly paying attention: from production to consumption, on waste management and secondary raw materials that are reinserted in the economy. The actions delivered by the Commission since the adoption of the Circular Economy Action Plan include several legislative proposals, for example, establishing clear targets for waste recycling and an ambitious long-term path leading towards waste prevention and recycling (13).

Legislative proposals on waste, tabled by the Commission in December 2015, included a common EU target for recycling 65 % of municipal waste by 2030; a common EU target for recycling 75 % of packaging waste by 2030; a binding target to reduce landfilling to maximum of 10 % of municipal waste by 2030 (14).

Moreover, the objectives of the Circular Economy are to create a common method and a more developed cooperation between EU states in order to promote recycling and reuse, in relation to end of life management Landfill Directive (15) and Hazardous Waste Directive (16) are used.

The Landfill Directive entered into force in 1999 and established restrictions and controls over waste disposal to landfill; a new proposal in 2014 aims to “phasing out landfilling by 2025 for recyclable waste (including plastics, paper, metals, glass and bio-waste) in non-hazardous waste landfills, corresponding to a maximum landfilling rate of 25%”.

Hazardous Waste Directive identifies the wastes with hazardous properties. The Directive reports additional requirements on waste management, controlling storage, labelling, transportation and treatment.

The two tables below summarize the main FCH systems components, the materials for each part of them (from *D2.2 EoL technologies (2)*) and the main related directives for end of life. Table 1 reports the main components and materials of BoPs and related EU Directives, Table 2 reports the main components and materials of the stacks and the related EU Directives.

Table 1 – Main components and material of BoP (2) and the related EU Directives.

COMPONENTS		main components/ EoL waste	EU DIRECTIVES
BoP components	Blower or compressor	Metals, plastics	<ul style="list-style-type: none"> ▪ Directive 94/62/EC on packaging and packaging waste ▪ Directive 2008/98/EC on waste ▪ Directive 2004/12/EC - Packaging and Packaging Waste ▪ Council Regulation (EU) No 333/2011 - Iron, steel and aluminium scrap ▪ REACH Regulation ▪ Landfill Directive ▪ Hazardous waste directive ▪ Eco-design Directive 2009/125/EC
	Humidification membrane	Metals, plastics, polymers	
	Pumps	Metals, Teflon®, rubbers, plastics	
	Regulators	Metals, plastics, rubbers	
	Deionising filter	Metals, plastics, resins	
	Pipes	Metals, plastics, rubbers	
	Valves	Metals, plastics, nylon, Teflon®	
	Gaskets (piping system)	Paper, plastics, rubbers	
	Thermal insulation system	Mineral wool, fibreglass	
	Heat exchangers	Metals	
	Thermal insulation system	Mineral wool, fibreglass	
	Heat exchangers	Metals	
	Water condensers	Stainless steel	
Water condensers	Stainless steel		
ancillary BoP components	PCBs	Metals, plastics, semiconductors, precious metals	<ul style="list-style-type: none"> ▪ Directive 2012/19/EU about WEEE ▪ RoHS Directive 2011/65/EU ▪ Directive 2008/98/EC on waste ▪ Landfill Directive ▪ Eco-design Directive 2009/125/EC
	Power conditioning system	Metals, plastics, semiconductors, precious metals	
	Sensors	Plastics, precious metals, semiconductors, glass	
Other components	batteries	Lithium ion/	Directive 2006/66/EC on batteries and accumulators and waste batteries and accumulators
	FCH external cabinet	metal (ferrous material, aluminium...)	<ul style="list-style-type: none"> ▪ Directive 94/62/EC on packaging and packaging waste ▪ Directive 2008/98/EC on waste ▪ Directive 2004/12/EC - Packaging and Packaging Waste

Table 2 – Main components and material of stacks (2) and the related EU Directives

FCH stacks		main components /EoL waste	EU DIRECTIVES
PEMFC	Electrolyte	Perfluoro-sulphonic acid (Nafion® type)	<ul style="list-style-type: none"> ▪ REACH Regulation ▪ WEEE Directive ▪ landfill Directive ▪ Hazardous Waste Directive ▪ Directive 2008/98/EC on waste
	anode and cathode GDL	Carbon-based material (cloth, felt, foam or paper) treated with hydrophobic acid Metallic mesh or cloth (e.g. stainless steel)	
	anode and cathode catalyst layer	Platinum/Pt-alloys/Catalyst support (carbon, metal oxides, carbides, etc.)	
	interconnection	Graphite/carbon-polymer composites/Aluminium/metal alloys	
	sealant	Plastics/elastomer	
PEMWE	Electrolyte	Perfluoro-sulphonic acid (Nafion® type)	
	anode and cathode GDL	Thermally sintered Ti, Ti/stainless steel, Graphite/graphite composites (only possible on cathode side)	
	anode catalyst layer	Iridium/Ir-alloys; Ruthenium/Ru-alloys	
	cathode catalyst layer	Platinum/Pt-alloys	
	interconnection	Coated Ti/Ti-alloys	
	sealant	Plastics/elastomer	
AWE	Electrolyte	Potassium hydroxide	
	anode	Precious metals/plastics	
	cathode	Raney-Nickel/plastics	
	diaphragm	PTFE/Polymers	
	interconnect	Plastics/elastomer	
	sealant	Plastics	
SOFC	Electrolyte	Ytria-stabilised zirconia	
	anode	nickel oxide/nickel	
	cathode	Strontium-doped lanthanum chromate	
	interconnect	Doped lanthanum chromate; Inert metals/alloys	
	sealant	Glass/glass-ceramic, ceramic	

2.2.1 End of life of balance of plant components in FCHs

There are a lot of different types of accessories inside a fuel cell system, as mentioned in point 1.3, and they are mainly made of metals and plastics. These accessories must be disassembled from the stack and the best solutions for the reuse and recycling according European or local directives must be taken.

The usual rule of reusing or recycling as much as possible is always valid. Pumps, pipes and accessories need to be easily separable from the core (here comes into play the Eco Design Directive) and a fine, appropriate and correct life cycle follows for each component, in compliance with Local and European Directives.

Common materials and devices recycling are always profitable for economic and above all environmental conditions and should not be neglected. The BoP components at end of life fit the WFD (11), the landfill Directive (15) and the Hazardous Waste Directive (16).

2.2.2 Electronic parts in FCHs as waste electrical & electronic equipment (WEEE)

Inside the FCH there are different types of electric and electronic parts (e.g. cables, PCB circuits, electric components, electronic components, controlling devices and sensors, inverter, etc.) (see [Figure 6](#)) which must be properly processed when the system reaches the end of life. These components are considered as EEE (Electrical Electronic Equipment) and proceeded as WEEE (Waste Electrical Electronic Equipment).

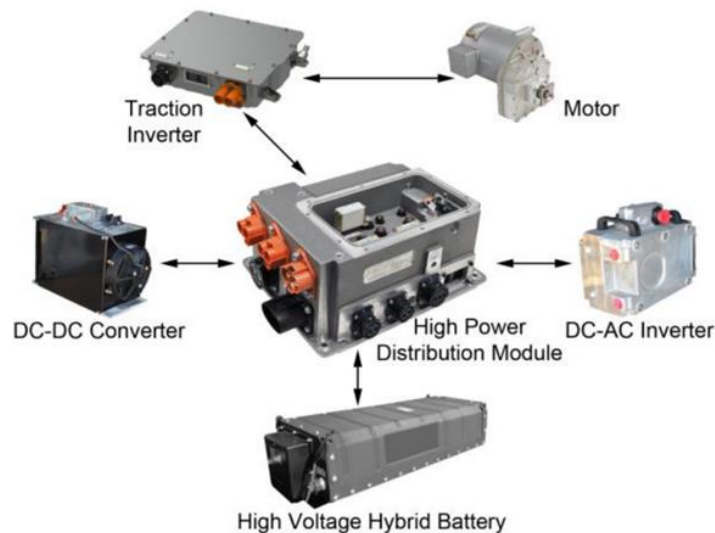

Figure 6 –Electrical components in a fuel cell system

WEEE is a complex mixture of materials and components that, because of their hazardous content, and if they are not properly managed, can cause major environmental and health problems. Thus, in order to improve the environmental management of WEEE, to contribute to a circular economy and enhance resource efficiency the improvement of collection, treatment and recycling of electronics at the end of their life is essential.

In relation to electronic components end of life there are two directives:

The first directive is WEEE Directive, Directive 2002/96/EC (8), that was active in February 2003. In December 2008, the European Commission proposed to revise the Directive in order to tackle the fast

increasing waste stream. The new WEEE, Directive 2012/19/EU (17), entered into force on 13 August 2012 and became effective on 14 February 2014. The purpose of the new directive is the same of Directive 2002/96/EC with the addition of PV, with immediate effect (18).

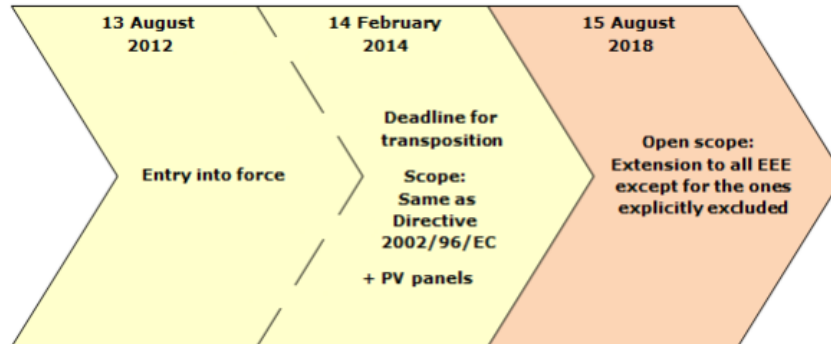

Figure 7 – Directives on WEEE from 2002 to 2018 (18).

Starting from 15 August 2018 the WEEE Directive (17) will include all EEE, except for all the ones explicitly excluded.

The second directive, RoHS I Directive, Directive 2002/95/EC (7), on restriction of use of hazardous substances in electrical and electronic equipment has been active since 2003 and after substituted with the recast RoHS II Directive, Directive 2011/65/EU (19). The recast does not add new substances to the restricted list reported in the previous directive, but the maximum tolerated concentration values are reported:

Substance	Maximum conc. Value (%)
Lead	0,1
Mercury	0,1
Cadmium	0,1
Hexavalent chromium	0,1
Polybrominated biphenyls (PBB)	0,1
Polybrominated diphenyl ethers (PBDE)	0,1

Table 3 – maximum tolerated concentration value (20)

The RoHS II Directive is applied to electrical and electronic equipment, it is classified under the categories reported in the Annex I-Categories of electrical and electronic equipment of this directive. The categories are:

1. Large household appliances
2. Small household appliances
3. IT and telecommunications equipment
4. Consumer equipment
5. Lighting equipment
6. Electrical and electronic tools (with the exception of large-scale stationary industrial tools)
7. Toys, leisure and sports equipment

8. Medical devices
9. Monitoring and control instruments including industrial monitoring and control instruments
10. Automatic dispensers
11. Other electrical and electronic equipment not covered by any of the categories above

The first 10 categories are also reported in the WEEE Directive, the 11th new category is added in RoHS II Directive.

These directives apply only to “electrical and electronic equipment” so defined in the Article 3.1: “electrical and electronic equipment or EEE means the equipment which is dependent on electric currents or electromagnetic fields in order to work properly and the equipment for the generation, transfer and measurement of such currents and fields and designed for use with a voltage rating not exceeding 1 000 volts for alternating current and 1 500 volts for direct current” (17).

The Directive RoHS II refers also to cables and spare parts as reported in the Article 4 Prevention, “including cables and spare parts for its repair, its reuse, updating of its functionalities or upgrading of its capacity ...”. Cables are “all cables with a rated voltage of less than 250 volts that serve as a connection or an extension to connect EEE to the electrical outlet or to connect two or more EEE to each other” and spare parts are “separate parts of an EEE that can replace a part of an EEE. The EEE cannot function as intended without that part of the EEE. The functionality of EEE is restored or is upgraded when the part is replaced by a spare part”.

The Table 7 reports the transposition of the directive in each member state.

Name	Name (in English)	Ref.
European Union	Directive 2012/19/EU of the European Parliament and of the Council of 4 July 2012 on waste electrical and electronic equipment (WEEE).	(16)
Spain	Real Decreto 110/2015, de 20 de febrero, sobre residuos de aparatos eléctricos y electrónicos.	Royal Decree 110/2015 of 20 February on waste electrical and electronic equipment. (21)
Italy	Attuazione della direttiva 2012/19/UE sui rifiuti di apparecchiature elettriche ed elettroniche (RAEE).	Implementation of Directive 2012/19 / EU on waste electrical and electronic equipment (WEEE). (22)
Slovenia	Uredba o odpadni električni in elektronski opremi.	Regulation on waste electrical and electronic equipment. (23)
France	Décret no 2014-928 du 19 août 2014 relatif aux déchets d'équipements électriques et électroniques et aux équipements électriques et électroniques usages.	Decree No. 2014-928 of 19 August 2014 on waste electrical and electronic equipment and used electrical and electronic equipment. (24)
Portugal	Decreto-Lei n.º 67/2014. D.R. n.º 87, Série I de 2014-05-07 Ministério do Ambiente,	Decree-Law No. 67/2014. DR No. 87, Series I of 2014-05-07 Ministry of the (25)

Name	Name (in English)	Ref.
	Ordenamento do Território e Energia Aprova o regime jurídico da gestão de resíduos de equipamentos elétricos e eletrónicos, transpondo a Diretiva n.º 2012/19/UE, do Parlamento Europeu e do Conselho, de 4 de julho de 2012	Environment, Spatial Planning and Energy Approves the legal regime for the management of waste electrical and electronic equipment, transposing Directive 2012/19 / EU of the European Parliament and of the Council of 4 July 2012
Netherland	Regeling van de Staatssecretaris van Infrastructuur en Milieu, van 3 februari 2014, nr. IENM/BSK-2014/14758, houdende vaststelling regels met betrekking tot afgedankte elektrische en elektronische apparatuur (Regeling afgedankte elektrische en elektronische apparatuur)	Regulations of the Secretary of State for Infrastructure and the Environment of 3 February 2014, No. IENM / BSK-2014/14758, laying down rules for waste electrical and electronic equipment (Disposal of Electrical and Electronic Equipment) (26)
Sweden	Föreskrifter (2013:02) om ändring av Naturvårds-verkets föreskrifter (NFS 2005:10) om yrkesmässig förbehandling och återvinning av avfall som utgörs av elektriska eller elektroniska produkter	Regulations (2013: 02) amending the Swedish Environmental Protection Agency's Regulations (NFS 2005: 10) on professional pre-treatment and recycling of waste electrical and electronic equipment (27)
Hungary	A Kormány 197/2014. (VIII. 1.) Korm. rendelete az elektromos és elektronikus berendezésekkel kapcsolatos hulladékgazdálkodási tevékenységekről	The Government 197/2014. (VIII.1.) Government Decree on Waste Electrical and Electronic Equipment Management Activities (28)

Table 4 – Member states transposition of the Directive 2000/53/EC

The WEEE Directive encourages the cooperation between producers and recyclers in order to facilitate re-use, dismantling and recovery of WEEE. Through eco-design it is possible to reach the main WEEE Directive targets.

The WEEE Directive establishes recycling and recovery targets for specific categories of domestic and industrial electrical and electronic equipment, and places the responsibility on equipment manufacturers to demonstrate compliance. The targets established by the directive range from 50 % to 80 % of recycling of components and materials by weight, and from 70 % to 80 % recovery, including material burnt for energy generation purposes.

Within these guidelines there are materials that can be recycled and devices that can be reused, and this is boosted in each European member state by EU.

The WEEE components extracted by the removal of FCH systems can then follow the current WEEE legislation.

The electronic parts in FCH system (control circuit and electronic devices) must be separated from the FCH core and follow the dismantling and recycling in accordance with Directive 2012/19/EU about WEEE.

The collaboration between producer and recycling plants must be fostered for a better dismantling and recovering of WEEE. The manufacturer cannot produce a FCH when project specifications prevent the dismantling or recycling.

A treatment for removing all the fluids in accordance with Annex VII of the Directive 2012/19/EU (17) is necessary.

Member States shall encourage the development of new recovery, recycling and treatment technologies.

Member States should take the necessary measures to ensure producers providing information free of charge about the preparation for re-use and treatment in respect of each type of new EEE placed for the first time on the EU market.

2.2.3 Hydrogen FCEV (Fuel cell vehicles) on end of life vehicles

Fuel cell electric vehicles are very similar to battery electric cars, relying purely on electricity for power. However, apart from batteries, a tank of compressed hydrogen provides the energy. The gas is fed into the fuel cells, which is the essential component of the vehicle. FCEVs are also hybrid vehicles using a battery that recover and store the braking energy. The energy produced with the battery mainly serves to reduce the peak demand from the fuel cell during the acceleration phase. As reported in the Technology Roadmap Hydrogen and Fuel cells (29), today around 550 FCEVs are running chiefly in demonstration projects, mainly distributed in EU, Japan, USA, Korea.

A more important increase is expected in the penetration of this kind of vehicles, mostly in the light-duty ones, among which a total of 520 000 units are expected to penetrate in EU, Japan, EEUU and Korea by 2020 and 700 000 units on the road by 2030 (30). More optimistic results are shown in the HyWays report (31) which, depending on the scenario, percentages of FCEV penetration considered by 2030 round between 4 % and 25 %. Taking into account the light-duty vehicles stock forecast of 313 000 000 (32) those percentages correspond from 12 523 600 to 78 272 500 FCEV in Europe by 2030 shown in Table 5. Other authors estimated the FCEV penetration in Japan in 100 000 units by 2020 and between 0.5 and 1 million units by 2025 (33).

		2020	2030	2040	2050
Penetration of FCEV over the total fleet (%)	Sc. 1	0.01 %	4.00 %	13.00 %	35.00 %
	Sc. 2	0.50 %	8.00 %	23.00 %	40.00 %
	Sc. 3	1.00 %	12.00 %	36.00 %	70.00 %
	Sc. 4	3.00 %	25.00 %	55.00 %	75.00 %
#FCEV	Sc. 1	27,605	12,523,600	45,517,550	135,513,000
	Sc. 2	1,380,225	25,047,200	80,531,050	154,872,000
	Sc. 3	2,760,450	37,570,800	126,048,600	271,026,000
	Sc. 4	8,281,350	78,272,500	192,574,250	290,385,000

Table 5 – FCEV penetration in Europe in different time horizons and scenarios

The related EU law on end of life vehicles Directive 2000/53/EC (34) aims to make dismantling and recycling of ELVs. The directive was transposed in the member states in 2002. The directive covers “any vehicle designated as category M1 or N1 defined in AnnexIIA of Directive 70/156/EEC (35) and three-wheeled motor vehicles as defined in Directive 92/62/EEC (36), but excluding motor tricycles”.

This directive, according to the circular economy concepts, is for an appropriate eco-design concept, providing for the elimination of hazardous substances in the vehicles and establishing high reuse/recycling/recovery targets (37).

The main points for FCEV in Directive 2000/53/EC (34) are:

- In vehicles, the reuse&energy recovery shall be 95% and reuse&recycle shall be 85% by an average weight per vehicle and year (See Table 6). It would be that if the vehicle is powered by a Fuel Cell system, the FCH must be recycled in high percentage as the rest of the vehicle.
- Member States shall take the necessary measures to ensure the manufacturers of components used in vehicles making them available to authorized treatment facilities requiring appropriate information concerning dismantling, storage and testing of components which can be reused.
- Member States shall require in each case the relevant economic operators to publish information about the correct way to recover, recycle, dismantling and in general the treatments about the EOL of FCH and other components.

As a part of a vehicle, the PEMFC is included in Directive 2000/53/EC (34) on end-of-life vehicles and they must be recycled in a high percentage as parts of the vehicle, so PEM developers should ensure the recycling targets set at up to 85% of vehicle/product by weight.

The table below reports the ELV directive in various countries (38).

STATES	ELV directive	Target vehicles	Recycling target
EU	Directive 200/53/EC Of The European Parliament And Of The Council of 18 September 2000 on end-of-life vehicles (enforced in 2000) http://eur-lex.europa.eu/legal-content/EN/TXT/PDF/?ui=CELEX:02000L0053-20130611&qid=1405610569066&from=EN	M1, N1	Until 2006: Reuse+Recovery: 85% Reuse+Recycle: 80% Until 2015: Reuse+Recovery: 95% Reuse+Recycle: 85%
Japan	Law for the Recycling of End-of-Life Vehicles (enforced in 2005) http://www.japaneselawtranslation.go.jp/law/detail/?id=127&vm=02&re=02	All vehicles (including buses, trucks, etc...) with the exception of two-wheeled vehicles	Airbag: 85% ASR: 70% (from 2015 onwards) 50% (2010 to 2014) 30% (2005-2009)
Korea	Act for Resource Recycling of Electrical/Electronic Equipment and vehicles (enforced in 2008) http://www.rsjtechnical.com/images/Documents/Korea_RoHS_ELVApril_2007_EcoFrontier.pdf	M1, N1	Until 2014: Material+energy recovery: 85% (of which energy recovery rate is within 5%) After 2015: Material+energy recovery: 95% (of which energy recovery rate is within 10%)
China	End-of-Life Vehicles Recycling Regulation (enforced in 2001) [34] Automotive Products Recycling Technology Policy (declared in February 2006)	M1, M2, M3, N1, N2, N3	Possibility of recycling: 2010: about 85% (material recycling of 80% or more) 2012: about 90% (material recycling of 80% or more) 2017: about 95% (material recycling of 85% or more)
US	Resource Conservation Recovery Act Clean Air Act, etc...	no regulation	No specific goals (95% of ELVs enter the recycling route, of which 80% of the materials are recycled)

M1, 4-wheeled vehicles with seating capacity of nine or less, including passenger vehicles; M2, seating capacity of nine or more, vehicle weight under 5 000 kg; M3, vehicle with seating capacity of nine or more, vehicle weight over 5 000 kg; N1, freight vehicle with maximum load capacity under 3 500 kg; N2, maximum load capacity of 3 500 kg or more, freight vehicle weight under 12 000 kg; N3, freight vehicle with maximum load capacity of 12 000 kg or more.

Table 6 – ELV directive in various countries

In relation to EU, Japan, Korea and China, the ELV management system is direct, based on legislation, in the US it is based on market mechanisms and environmental regulations.

The Table 6 reports also the reaching target in relation to reuse+recovery and reuse+recycling. In the EU, the related Directive was enforced in 2000, in Korea in 2008 and in Japan in 2005, with recycling targets separated for airbags, refrigerant gas and ASR and not for whole ELV as in the other countries.

The Table 7 reports the transposition of the directive in EU Member States.

	Name	Name (in English)	Ref.
European Union		Directive 2000/53/EC of the European Parliament and of the Council of 18 September 2000 on end-of life vehicles	(34)
Spain	Real Decreto 20/2017, de 20 de enero, sobre los vehículos al final de su vida útil.	Royal Decree 20/2017, of 20 January, on end-of-life vehicles.	(39)
Italy	Decreto Legislativo n° 209 del 24/6/2003 - Attuazione della Direttiva 2000/53 relativa ai veicoli fuori uso. GURI - Serie generale, n° 182 del 07/08/2003 p. 5	Legislative Decree no. 209 of 24/6/2003 - Implementation of Directive 2000/53 on out of use vehicles. GURI - General Series, No. 182 of 07/08/2003 p. 5	(40)
Slovenia	Uredba o taksii na obremenjevanje okolja zaradi nastajanja izrabljenih motornih vozil	Regulation on tax on environmental pollution of-life vehicles	(41)
Germany	Gesetz über die Entsorgung von Altfahrzeugen (Altfahrzeug-Gesetz- Altfahrz.G) vom 21/06/2002 BGBl. n° 41 Teil I du 28/06/2002 p. 2199	Act on the Disposal of End-of-Life Vehicles (End-of-Life Vehicles Act) from 21/06/2002 Federal Law Gazette n° 41 Part I of 28/06/2002 p. 2199	(42)
Bulgary	Наредба за излезлите от употреба моторни превозни средства	Ordinance on End-of-Life Vehicles	(43)

Table 7 – Member states transposition of the Directive 2000/53/EC.

The document “End-of-life vehicles recycling in Germany and recent developments” (44) presented in the International workshop on 3R Strategy and ELV Recycling in 2012 in Japan, reports a global outlook 2030 with new hybrid and electric vehicles per year about 40-50 million and a target 2020 in Germany of 1 million of electric vehicles. This implies the needs and revisions of critical raw materials for electric vehicles (45).

The table 8 reports the raw material requirements (2010) for each electric vehicle component (44). A comparison between conventional powertrain and electric motor is reported.

E-Vehicles parts	gold	silver	copper	gallium	indium	germanium	platinum	palladium	ruthenium	neodymium	praseodymium	dyprosium	terbium
electric motor	N.U.	N.U.			N.U.	N.U.	N.U.	N.U.	N.U.				
power electronic										N.U.	N.U.	N.U.	N.U.
battery/cables	N.U.	N.U.		N.U.	N.U.	N.U.	N.U.	N.U.	N.U.	N.U.	N.U.	N.U.	N.U.
fuel cell components (FC system, stack, H2 tank)	N.U.	N.U.			N.U.	N.U.		N.U.	N.U.				
charging station, pillar incl. Charging cable	N.U.						N.U.	N.U.	N.U.	N.U.	N.U.	N.U.	N.U.
★ other electrical components (steering, brakes, electronics)	N.U.	N.U.		N.U.	N.U.	N.U.	N.U.	N.U.	N.U.	N.U.	N.U.	N.U.	N.U.
★ ICE applications (catalyst converter, combustion engine, alternator)	N.U.	N.U.		N.U.	N.U.	N.U.			N.U.	N.U.	N.U.	N.U.	N.U.
★ standard in-car cabling	N.U.			N.U.	N.U.	N.U.	N.U.	N.U.	N.U.	N.U.	N.U.	N.U.	N.U.
	amount per vehicle in kg range												
	amount per vehicle in g range												
	amount per vehicle in mg range												
N.U.	not used												

★ Conventional powertrain

Table 8 – Raw material demand for electric vehicles

The document reports the main supply risks concerning raw materials used in electric cars (2030 outlook (44)):

- Dysprosium (rare earths) demand will increase in 2020 6 time the global production, with a high environmental impact;
- Copper quantity per vehicle will increase up to three times;
- Gold, silver and palladium, the demand will increase.

By replacing ICE vehicles with FCEVs, a reduction in the use of aluminium, brass, iron and plastics is expected. By contrast, the quantity of batteries and PGMs used as catalyst is largely increased. Other materials like carbon cloth or paper, cobalt, nickel or titanium are added to the powertrains of new concept vehicles based on FCs. The advantage of reducing the use of metals like aluminium or iron, with high energy requirements in their manufacturing process, is minimized by the impact of the critical raw materials used in the manufacture of FCs for vehicles powertrains, like cobalt, PGMs (Pt mainly) and, with minor impact, nickel or carbon compounds.

Precious metals as silver, gold, palladium and platinum also play a part in the components for electric mobility: platinum, in particular, is important for fuel cell vehicles.

The literature reports variable compositions of precious metals in the catalytic converters based on Pt: Rh: Pd, with the average quantities of PGM equal to 1.5 g of Pt, 0.6 g of Pd, and 0.02 g of Rh (46).

In a FCEV, the amount of Pt is around 0.5 g/kW, so for a car of 100 kW of power the Pt quantity is around 50 g.

There will be the need to include electro-mobility in a sustainable transportation concept, to develop a more environmental friendly method of mining main metals and to promote recycling. This could be implemented through a more detailed research on recycling methods and optimization and through an implementation and amendment of the EU and regional legislations.

2.2.4 Batteries in a FCH system end of life

The FC systems are equipped with batteries for starting and for the storage of electricity produced in excess. Also in the battery, like in the rest of the system, there are materials that have to be recovered and in the Directive 2006/66/EC, Batteries Directive (47), there are information about the waste batteries treatment.

Fuel Cells are considered as battery and also have a battery support system (for accumulating the produced energy and for starting energy production)

The Directive 2006/66/EC (47) on batteries and accumulators and waste batteries and accumulators (48) entered in force in September 2006 and it was transposed in the Member states in September 2008. The Directive was amended three times: in 2008, it was modified twice as regards the implementing powers conferred on the Commission and as regards placing batteries and accumulators on the market (Directive 2008/12/EC (49) and Directive 2008/103/EC (50)) and in 2013 it was amended to remove exemptions regarding the use of cadmium in portable batteries used in cordless power tools (article 4.3) and with respect to the use of mercury in button cells (article 4.2) (51). The amended directives entered into force on 30 December 2013 and it should have been transposed by Member States by 1 July 2015.

This directive regulates the placing on the market, collection, treatment, recycling and disposal of batteries into EU with the aim of improving their environmental performance. The directive is related to all batteries, hazardous one and not, and containing metals which are recyclable. The directive covers all types of batteries: Lead-acid, Nickel Cadmium (Ni-Cd), Lithium-Primary, Lithium-Ion (Li-ion), Zinc Alkaline, etc. It restricts the use of mercury in all batteries and cadmium in portable batteries. The Directive does not include fuel cells, classical capacitors and super capacitors.

The directive is in strict relation with the Directive 2000/53/EC (34) and Directive 2002/96/EC (8). The Article 2 of Directive 2002/96/EC (8) reports that it “shall apply without prejudice to them”.

Both the ELV and the Batteries Directive contain substance restrictions and both establish the principle of “producer responsibility”: if a car producer installs a battery in a car and introduces it in the market, he is considered a “battery producer” too.

Regarding treatment and recycling, the ELV Directive (34) reports that the batteries have to be removed from ELV and after collected; the Batteries Directive (47) explains that the recycling process should comply with the requirements laid down in Annex III:

“PART A: TREATMENT 1. Treatment shall, as a minimum, include removal of all fluids and acids. 2. Treatment and any storage, including temporary storage, at treatment facilities shall take place in sites with impermeable surfaces and suitable weatherproof covering or in suitable containers. PART B: RECYCLING 3. Recycling processes shall achieve the following minimum recycling efficiencies: (a) recycling of 65 % by average weight of lead-acid batteries and accumulators, including recycling of the lead content to the highest degree that is technically feasible while avoiding excessive costs; (b) recycling of 75 % by average weight of nickel-cadmium batteries and accumulators, including recycling of the cadmium content to the highest degree that is technically feasible while avoiding excessive costs; and (c) recycling of 50 % by average weight of other waste batteries and accumulators”.

	Name	Name (in English)	Ref.
European Union		Directive 2006/66/EC of the European Parliament and of the Council of 6 September 2006 on batteries and accumulators and waste batteries and accumulators and repealing Directive 91/157/EEC.	(47)
Spain	Real Decreto 106/2008, de 1 de febrero, sobre pilas y acumuladores y la gestión ambiental de sus residuos.	Royal Decree 106/2008, of 1 February, on batteries and accumulators and the environmental management of their waste.	(52)
Italy	Decreto Legislativo 20 novembre 2008, n. 188 Attuazione della direttiva 2006/66/CE concernente pile, accumulatori e relativi rifiuti e che abroga la direttiva 91/157/CEE	Legislative Decree 20 November 2008, no. 188 Implementation of Directive 2006/66/EC on batteries, accumulators and waste and repealing Directive 91/157/EEC	(53)
Slovenia	Uredba o ravnanju z baterijami in akumulatorji ter odpadnimi baterijami in akumulatorji.	Decree on waste batteries and accumulators and waste batteries and accumulators.	(54)
Czech	Vyhláška č. 170/2010 Sb., o bateriích a akumulátorech a o změně vyhlášky č. 383/2001 Sb., o podrobnostech nakládání s odpady, ve znění pozdějších předpisů.	Decree No. 170/2010 Coll., On batteries and accumulators and amending Decree No. 383/2001 Coll., On the details of waste management, as amended.	(55)
Austria	Verordnung des Bundesministers für Land- und Forstwirtschaft, Umwelt und Wasserwirtschaft über die Abfallvermeidung, Sammlung und Behandlung von Altbatterien und -akkumulatoren (Batterienverordnung).	Ordinance of the Federal Minister for Agriculture, Forestry, Environment and Water Management on Waste Prevention, Collection and Treatment of Waste Batteries and Accumulators (Ordinance on Batteries).	(56)
Greece	Μέτρα, όροι και πρόγραμμα για την εναλλακτική διαχείριση των αποβλήτων ηλεκτρικών στηλών και συσσωρευτών σε συμμόρφωση με τις διατάξεις των οδηγιών, 2006/66/EK «σχετικά με τις ηλεκτρικές στήλες και τους συσσωρευτές και τα απόβλητα ηλεκτρικών στηλών και συσσωρευτών και με την κατάργηση της οδηγίας 91/157/EOK» και 2008/103/EK «για την τροποποίηση της οδηγίας 2006/66/EK σχετικά με τις ηλεκτρικές στήλες και τους συσσωρευτές και τα απόβλητα ηλεκτρικών στηλών και συσσωρευτών, όσο αφορά την τοποθέτηση ηλεκτρικών στηλών και συσσωρευτών στην αγορά», του Ευρωπαϊκού Κοινοβουλίου και του Συμβουλίου.	Measures, conditions and program for the alternative management of waste batteries and accumulators in compliance with the provisions of Directives 2006/66 / EC "on batteries and accumulators and waste batteries and accumulators and repealing the Directive 91/157 / EEC 'and 2008/103 / EC' amending Directive 2006/66 / EC on batteries and accumulators and waste batteries and accumulators as regards the installation of batteries and accumulators in Market ", of the Euro - the European Parliament and the Council.	(57)
Estonia	Kasutatud patareide ja akude käitlusnõuded	Used batteries and accumulators for treatment	(58)

Table 9 – Member states transposition of the Directive

3. Barriers for deployment of FCH technologies: regulatory barriers analysis

FCHs and FCH systems are growing in the last years, due to the interesting alternative to conventional systems and they offer attractive possibilities for efficient electricity generation across many applications.

During their market deployment stage, and as a future market consolidation, most FCH technologies will substitute other technologies and products that are currently consuming critical raw materials. A clear example is the automotive industry, where FCEVs based on PEMFCs are expected to be progressively replacing ICE vehicles.

However, there are still many barriers to the deployment of FCH systems, mainly related to the costs of the materials, assembly, reliability and durability of the system, sensitivity of end users, lack of distribution and infrastructures.

The European Commission has detected that an increase in legislative actions about FCHs, with the objective to control the environmental impact of the product in his life cycle, coincides with a successful commercialization of them. Legislation evolves continuously, so in this evolution there is the availability to allocate detailed analysis and mainly barriers with continuous design development prior commercialization of FC.

The EU, along with the Circular Economy concepts, and in strict cooperation with regional authorities, universities, stakeholders, innovators, etc., has detected preliminary barriers to innovation, mainly regulatory barriers. The main objective was to help innovators to overcome the regulatory obstacles.

The new Action Plan includes the creation of "Innovation Deals" with the objective to detect the main barriers to innovation and quickly addressing legislative barriers, shortening the time for a market uptake. It is in this phase when the EU Commission collected 32 expressions of interest from 14 member states and some topics which identified the major barriers to innovation.

In 2017 two Innovation Deals will be focused on regulatory barriers on sustainable wastewater treatment, and e-mobility and recycling of batteries. In this phase of innovation and re-working of legislation when specific studies on FCH systems can be allocated.

Industry feels not only the pressure from the current legislation, but it is also anticipating future regulations. The stringency of laws in some countries is still lacking and future improvements can easily motivate companies to enhance their environmental performance.

Coming from the EU legislation analysis it is possible to detect some barriers for the deployment of FCH technologies.

3.1 Lack of specific legislations on FCH systems

In Europe there are a lot of waste and waste-management legislation, but they are not directly applicable to fuel cells, mandatory recycling targets established for vehicles (ELV Directive (34)) and electrical and electronic equipment (WEEE Directive (17)) may have a direct influence on the requirements for the end-of-life management of fuel cells used in these applications. Another important point to analyse is the environmentally responsible management of the products, some directives, as WEEE and ELV, reports recycling targets, the same for batteries, but analysing large stationary fuel cells, no legislation is applicable to this specific use of FCH technologies.

Fuel cell developers (as all the other products developers) are responsible for the recovery and recycling all parts of FCH systems, so possible failures on it would have an impact on the technology development and its entry into the market.

3.2 Hazardous materials in FCH technologies and barriers on REACH Regulation

From the list of materials reported on “D 2.1-Identification of critical raw materials” (1), for each considered technology (SOFCs, PEMFCs, PEMWEs, and AWEs) some conclusions can be drawn:

SOFCs materials mainly consist of REE which makes this FCH technology critical from the perspective of the EU states. These materials are classified as rather costly and hazardous too. The main hazardous materials are: Nickel-based oxide doped with YSZ and nickel in the anode side (Hazardous-cat 1 carcinogen); Strontium-doped lanthanum manganite (hazardous-irritant) in the cathode side; Doped lanthanum chromate (hazardous-irritant, harmful) in interconnections.

PEMFCs materials are mainly low-to-medium in cost with the exception of Pt or Pt-alloy catalysts. Pt and graphite, which is typically used for bipolar plates and represents a significant proportion in weight and volume of the stack, are classified as critical for the EU states. Most materials used in this FCH technology are classified as non-hazardous. The detected hazardous material is polybenzimidazole (PBI) doped with H₃PO₄ (used in HTPEM) (hazardous, corrosive) which can be found in the electrolyte.

PEMWEs materials are more expensive compared to the PEMFCs. The OER catalysts are based on REE while the HER catalysts are based on Pt, which means that these materials are also classified as critical and expensive. The materials are mainly non-hazardous with the exception of the REE used for OER catalysts. The main hazardous materials are: Iridium and Ir-alloys (hazardous-irritant) and Ruthenium and Ru-alloys (hazardous-toxic and carcinogen) in the catalyst anodic layer.

AWEs materials are usually low in costs with the exception of both the anode and the cathode catalysts, which are also classified as critical for the EU states. This FCH technology is also classified as rather hazardous since the alkaline electrolyte in liquid form is used. Also, Ni-based catalyst and asbestos diaphragms, used in older types of AWEs, are classified as carcinogen. The main hazardous materials are: Potassium Hydroxide (corrosive) in the electrolyte; Raney-Nickel (carcinogen) in the cathode side; Asbestos (carcinogen) in the membrane.

The first barrier to innovation and commercialization of the FCH systems is the presence of hazardous materials, they could affect the deployment mainly in relation to future restriction on use of hazardous materials.

Nickel oxide used in the anode side of a SOFC stack is classified as SVHC and this classification could lead to a potential prohibition. Research activities on new potential materials are ongoing but nickel based catalysts are the most active until now (59). Also, the presence of nickel based alloys, mainly in the balance of plant of Solid Oxide fuel cells, always takes the issue with hazardous materials and the evaluation of alternative materials.

Another barrier is related to the supply chain and the related costs in phase of registration of all manufactured and chemical substances. The main barrier is due to the specific materials exclusively used in FCHs and manufactured at low volume by SMEs. Inability to source the required materials would be

prohibitive to commercial introduction and production. This increase in administrative burden could affect the costs of materials.

3.3 Barriers related to critical raw materials (connected with the Eco-Design Directive)

The scarcity of critical raw materials, with their economic importance, together with the distribution of them in specific geographical areas (mainly outside of Europe), makes it necessary to explore new avenues towards reduction or replacing of these critical materials. The FCH industry is aware of the situation, taking into account the problem from their designing step in this deployment stage of the technology.

Other industries that are currently in the market are directly facing this problem nowadays. The automotive industry, the industry of electronic devices (flat – screen televisions, smartphones, etc.) and others rely on a range of materials such as antimony, cobalt, lithium, tantalum, tungsten and molybdenum. The same problem of scarcity of critical raw materials applies to the new environmentally friendly products, such as the FCH products. For example, electric cars require lithium for their batteries, neodymium in their electric motors and car catalyst based on platinum; high speed-trains cobalt and samarium; and solar panels require indium, gallium, selenium and tellurium (60).

Different replacing techniques of critical raw materials have been analysed in the framework of “The Critical Raw Materials Innovation Network (CRM_InnoNet)”, an initiative of the European Commission which aims at creating an integrated community that will drive innovation in the field of critical raw materials substitution (61). The EC is really aware of the benefits that the substitution of critical raw materials can provide to the EU industry. The most promising techniques for CRM InnoNet are:

- Direct replacement of one substance or material with another (e.g. in solar panels: indium tin oxide with organic polymers)
- Replacing a material with an entirely new technology (e.g. bio-enzymatic processes replacing metal catalysts)
- Services (e.g. a leasing model for electric car batteries could allow batteries to be swapped for a charged one rather than recharged, allowing for longer recharge times needing smaller quantities of critical raw materials).

The reduction techniques are more commonly applied by optimization techniques in the use of material resources in the R&D departments of the manufacturer companies. As an example, Toyota has reduced platinum loadings to around 30 g over the recent few years before presenting their commercial Fuel Cell Electric Vehicles (FCEV) (around 4 to 5 times more platinum than the one present in the catalyzer of a diesel equivalent class car, representing the cost in platinum less than 3 % of the total vehicle cost). Current improvements in nanotechnology are allowing reductions in metal loading without a loss of performance or durability (62).

The FCH industry has detected some raw materials:

- Platinum-group metals: used in PEMFCs and electrolyzers. The metallic elements that are used in the FCH industry are platinum (mainly), ruthenium and iridium. The main production and reserves of platinum are located in South Africa (73 % estimated world mined production and supply of platinum in 2012) and the current main uses are autocatalyst in petrol and diesel engines (40 % world demand 2012) and jewellery (36 % world demand in 2012) (61).

- Rare Earth Elements (REEs): used in SOFC. China dominates the world reserves of REE with a mine production of 95 000 tonnes (86.8 % of total) and a reserve of 55 000 000 tonnes (48.3 % of total) in 2012 (63).

The use of critical raw materials, mainly Pt based and REE, poses main problems mainly due to an increasing cost of materials and a decreasing availability that could impact in the production system and could limit its commercialization. This is an assessment that manufacturers must consider during design-phase.

3.4 Barriers on Hazardous waste and landfill Directives

Landfill Waste legislation (15) and mainly Hazardous Waste Directive (16) identifies the wastes with hazardous properties.

As reported above the FCHs systems and mainly the SOFC stacks are made of hazardous materials and so in the waste classification it is necessary to determinate if the waste from FCHs is hazardous or not. The waste classification starts from hazardous substances present in a waste stream, following the scheme reported below.

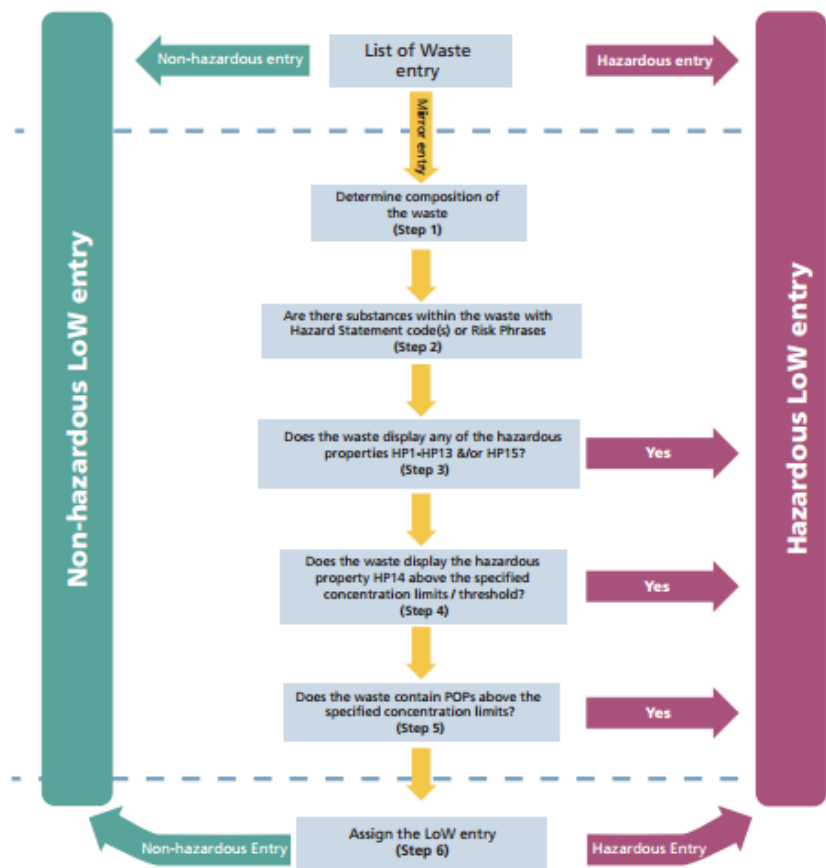

Figure 8 – Determination of hazardous or not-hazardous waste (64).

Starting from hazardous materials evaluation, the Hazardous Waste Directive (16) reports as permitted a nickel metal concentration up to 1wt% and a nickel oxides concentration up to 0.1wt%. If the waste contains higher concentration than the limit it could be a barrier for the system commercialization. The material evaluations in the eco-design phase must take into account the waste stream limitations.

The main barrier that comes from this aspect is a non-environmental beneficial image promoted by the FCHs manufacturers, producers, developers and it could delay the market entry of this technology.

However, the Landfill Directive (15) requires, if there are no waste disposal alternatives, to reduce through pre-treatment the amount of waste prior to the disposal to landfill. If these aspects will not be taken into account in design-phase, they could lead not to comply with the requirements of the directive, thus slowing down the future marketing of the product.

3.5 Barriers on WEEE and RoHS Directives

Inverters and DC converters fall under the definition of EEE as mainly reported in the Article 3.1.a of the WEEE Directive (8).

An inverter is an electrical device that changes direct current DC to alternate AC current, and it is commonly used in a fuel cell system.

Fuel cells produce a variable DC voltage that depends on the load current and cannot be used directly to supply a DC or AC load. For downstream application, it is necessary to convert the output voltage to a suitable and constant DC voltage level using power electronics. The DC/DC stabilises the output voltage of the fuel cell. The power electronics and power conditioning system is one of the key subsystems of the fuel cell power system that is required to convert DC electrical power generated by a fuel cell into usable AC power for APU applications.

Cable and connectors, used in a FCH system, have to transmit current, up to hundreds of amperes, at a high voltage level. They are inside EEE.

However, under existing legislation, components installed within large stationary power generation systems are perceived to lie outside the scope of the WEEE Directive. Therefore, any requirements to meet specified recycling targets would arise from future developments of this type of legislation.

RoHS Directive (7) drives the manufacturers to avoid the use of some components (lead, mercury, cadmium, hexavalent chromium, polybrominated biphenyls and polybrominated diphenyl ethers). In order to meet the requirements and a national implementing legislation, the substitution of these hazardous materials is needed.

3.6 Barriers on End-of-life Vehicles

The Directive related to ELVs (34) is directly applicable to FCHVs, but it presents restrictive targets for reuse & recovery and reuse & recycle, respectively of 95% and 85% of the vehicle by weight, so the FCHs developers have to guarantee the achieving goals in the end of life.

If these aspects will not be taken into account in the design-phase, they could lead not to comply with the requirements of the directive. This can slow down the future marketing of the product and damage to the environmental beneficial image promoted by the FCHs manufacturers.

3.7 Barriers on Eco-design Directives

Eco Design regulations have to date mainly addressed to the use-phase energy consumption. There is, however, potential for the reduction of other environmental impacts of energy-related products. A systematic integration of material efficiency requirements (e.g. product lifetime, recyclability, recycled content and/or design for higher efficiency in the use of raw materials) in the implementing measures of the Eco Design Directive has the potential to drive innovation for circular economy business models through a better product design.

Eco Design for resource efficiency can benefit consumers by making products more durable or easier to repair. It can help recyclers to disassemble products in order to collect valuable materials. It can contribute to save resources that are valuable for the environment and economy. Market signals are, however, not always sufficient to make this happen, in particular because the interests of producers, users and recyclers are not necessarily aligned. It is, therefore, essential to promote and boost improved product design, while at the same time preserving the internal market and enabling innovation (65).

FCHs manufacturers and developers are required to implement and provide evidence of eco-design. However, the Eco-design Directive does not mention FCH technologies explicitly, but it applies to all energy products.

The possibility to repair, remanufacture or recycle a FCHs system and its components and materials depends in large part on the initial design of the product. It is therefore crucial that these aspects are taken into account when investigating possible Eco Design implementing measures.

4. Conclusions

The report analyses the legislation on the material design and the end of life mainly related to fuel cell and hydrogen systems, so specific Directives are reported and related to each part of the FCH system:

- Eco Design Directive has to be consider in the whole FCHs system design, but also for the materials selection both FC stack that BoP components.
- REACH Regulation is to be considered in stack and BoP materials selection
- RoHS Directive is specific to material selection in power control systems
- WEEE Directive is related to electric and electronic parts in a fuel cell system
- Hazardous waste Directive has to be used for FC stacks and BoP components with hazardous materials
- ELV Directive can be used for FCHVs
- Batteries Directive is specific for EoL batteries installed in a FCH system.

The main barriers for the deployment of FCH technologies related to present legislations are here summarized:

- In relation to the FCH system design, FCHs manufacturers have to implement and provide evidence of eco-design. Specific chapters in the eco-design Directive on FCHs are required otherwise the FCH manufacturers may incur a negative impact of the product. Another fundamental aspect tied to Eco Design is related to the choice of materials during the design phase, it can positively impact on the cost of technology.

- In relation to the materials selection the present legislation on hazardous materials poses restrictions in the selection of substances. This implies the need for manufacturers to take into serious consideration this requirement because it might preclude the marketing of these systems.
- In relation to end of life management, recycling target could be too restrictive if the FCH developers will not put attention on them during the design phase and this could affect the technology's image. Barrier related to ELV Directive. However, the WEEE Directive poses an important issues due to the exclusion of large scale stationary industrial tools from the Directive. Therefore FCH developers should focus on strategies for end-of-life management of the stack in order to limit landfill waste and following recovery and recycling procedures taking them in account during the Eco Design phase. (59).
- Lack of a specific FCH Directive. As mentioned before some current Directives include FCH products or have to be taken in account with a FCH system, but the creation of a more detailed FCH relevant regulatory is needed.

5. References

1. A. Lotrič, M. Sekavčnik, B. Jurjevčič, M. Drobnič, M. Mori, R. Stropnik. Deliverable 2.1 Assessment of critical materials and components in FCH technologies [Internet]. 2016. Available from: <http://hytechcycling.eu/wp-content/uploads/D2.1-Identification-of-critical-materials.pdf>
2. A. Valente, M. Martín-Gamboa, D. Iribarren, J. Dufour. Deliverable 2.2 Existing end-of-life technologies applicable to FCH products [Internet]. 2016. Available from: <http://hytechcycling.eu/wp-content/uploads/D2.2-EoLtechnologies.pdf>
3. Masoni P, Zamagni A. Guidance document for performing LCA on fuel cells. 2011 Sep p. 109. Report No.: D3.3.
4. Wright EI, Rahimifard S. Strategic Decision Making for End-of-Life Management of Fuel Cells. In: Dornfeld DA, Linke BS, editors. Leveraging Technology for a Sustainable World [Internet]. Berlin, Heidelberg: Springer Berlin Heidelberg; 2012 [cited 2017 May 24]. p. 185–90. Available from: http://link.springer.com/10.1007/978-3-642-29069-5_32
5. Regulation (EC) n° 1907/2006, of 18 December 2006 concerning the Registration, Evaluation, Authorisation and Restriction of Chemicals (REACH), establishing a European Chemicals Agency, amending Directive 1999/45/EC and repealing Council Regulation (EEC) No 793/93 and Commission Regulation (EC) No 1488/94 as well as Council Directive 76/769/EEC and Commission Directives 91/155/EEC, 93/67/EEC, 93/105/EC and 2000/21/EC. 2006 Dec 18;
6. Directive 2009/125/EC of the European Parliament and of the Council of 21 October 2009 establishing a framework for the setting of Eco Design requirements for energy-related products [Internet]. Directive 2009/125/EC Oct 21, 2009. Available from: <http://data.europa.eu/eli/dir/2009/125/oj>
7. Directive 2002/95/EC of the European Parliament and of the Council of 27 January 2003 on the restriction of the use of certain hazardous substances in electrical and electronic equipment [Internet]. Available from: <http://eur-lex.europa.eu/legal-content/EN/TXT/?qid=1495616171230&uri=CELEX:32002L0095>
8. Directive 2002/96/EC of the European Parliament and of the Council of 27 January 2003 on waste electrical and electronic equipment (WEEE) [Internet]. Available from: <http://eur-lex.europa.eu/legal-content/EN/TXT/?qid=1495615615542&uri=CELEX:32002L0096>
9. European Commission. Communication from the Commission. Ecodesign Working Plan 2016-2019 [Internet]. 2016. Available from: http://www.eup-network.de/fileadmin/user_upload/2016/3rd_Working_Plan_com_2016_773.pdf
10. Commission Regulation (EU) No 1194/2012 of 12 December 2012 implementing Directive 2009/125/EC of the European Parliament and of the Council with regard to ecodesign requirements for directional lamps, light emitting diode lamps and related equipment.
11. Directive 2008/98/EC of the European Parliament and of the Council of 19 November 2008 on waste and repealing certain Directives [Internet]. Directive 2008/98/EC Nov 19, 2008. Available from: <http://eur-lex.europa.eu/legal-content/EN/TXT/?qid=1495611294290&uri=CELEX%3A32008L0098>
12. Dominic Hogg, Thomas Vergunst, Tim Elliott, Laurence Elliott, Christian Fischer, Birgitte Kjær, et al. Impact Assessment on Options Reviewing Targets in the Waste Framework Directive, Landfill Directive and Packaging and Packaging Waste Directive. Final Report. Report for the European

- Commission DG Environment under Framework Contract N° ENV.C.2/FRA/2011/0020 [Internet]. 2014. Available from: http://ec.europa.eu/environment/waste/pdf/target_review/Targets%20Review%20final%20report.pdf
13. European Commission. Report from the Commission to the European parliament, the Council, the European economic and social committee and the Committee of the regions on the implementation of the Circular Economy Action Plan [Internet]. 2017. Available from: http://ec.europa.eu/environment/circular-economy/implementation_report.pdf
 14. European Commission. Review of Waste Policy and Legislation [Internet]. 2016. Available from: http://ec.europa.eu/environment/waste/target_review.htm
 15. Council Directive 1999/31/EC of 26 April 1999 on the landfill of waste [Internet]. Available from: <http://eur-lex.europa.eu/legal-content/EN/TXT/?uri=celex:31999L0031>
 16. Council Directive 91/689/EEC of 12 December 1991 on hazardous waste [Internet]. Available from: <http://eur-lex.europa.eu/legal-content/EN/TXT/PDF/?uri=CELEX:31991L0689&from=EN>
 17. Directive 2012/19/EU of the European Parliament and of the Council of 4 July 2012 on waste electrical and electronic equipment (WEEE) [Internet]. Available from: <http://eur-lex.europa.eu/legal-content/EN/TXT/?qid=1495615843596&uri=CELEX:32012L0019>
 18. European Commission. Frequently Asked Questions on Directive 2012/19/EU on Waste Electrical and Electronic Equipment (WEEE) [Internet]. 2014. Available from: <http://ec.europa.eu/environment/waste/weee/pdf/faq.pdf>
 19. Directive 2011/65/EU of the European Parliament and of the Council of 8 June 2011 on the restriction of the use of certain hazardous substances in electrical and electronic equipment. Jun 8, 2011.
 20. The European Engineering Industries Association. Orgalime RoHS Guide, A practical Guide to understanding the specific obligations of Recast Directive 2011/65/EU on the Restriction of the Use of Certain Hazardous Substances in EEE (RoHS II) [Internet]. 2012. Available from: <https://www.certifico.com/component/attachments/download/890>
 21. Real Decreto 110/2015, de 20 de febrero, sobre residuos de aparatos eléctricos y electrónicos [Internet]. Real Decreto 110/2015. Available from: <http://eur-lex.europa.eu/legal-content/EN/ALL/?uri=NIM:223658&qid=1495618570221>
 22. Attuazione della direttiva 2012/19/UE sui rifiuti di apparecchiature elettriche ed elettroniche (RAEE). [Internet]. Available from: <http://eur-lex.europa.eu/legal-content/EN/TXT/?uri=NIM:214890&qid=1495618570221>
 23. Uredba o odpadni električni in elektronski opremi [Internet]. Available from: <http://eur-lex.europa.eu/legal-content/EN/TXT/?uri=NIM:228875&qid=1495618570221>
 24. Décret no 2014-928 du 19 août 2014 relatif aux déchets d'équipements électriques et électroniques et aux équipements électriques et électroniques usagés [Internet]. Available from: <http://eur-lex.europa.eu/legal-content/EN/TXT/?uri=NIM:219933&qid=1495618570221>
 25. Decreto-Lei n.º 67/2014. D.R. n.º 87, Série I de 2014-05-07 Ministério do Ambiente, Ordenamento do Território e Energia Aprova o regime jurídico da gestão de resíduos de equipamentos elétricos e eletrónicos, transpondo a Diretiva n.º 2012/19/UE, do Parlamento

- Europeu e do Conselho, de 4 de julho de 2012 [Internet]. Available from: <http://eur-lex.europa.eu/legal-content/EN/TXT/?uri=NIM:215715&qid=1495618570221>
26. Regeling van de Staatssecretaris van Infrastructuur en Milieu, van 3 februari 2014, nr. IENM/BSK-2014/14758, houdende vaststelling regels met betrekking tot afgedankte elektrische en elektronische apparatuur (Regeling afgedankte elektrische en elektronische apparatuur) [Internet]. Available from: <http://eur-lex.europa.eu/legal-content/EN/TXT/?uri=NIM:213457&qid=1495618570221>
 27. Föreskrifter (2013:02) om ändring av Naturvårds-verkets föreskrifter (NFS 2005:10) om yrkesmässig förbehandling och återvinning av avfall som utgörs av elektriska eller elektroniska produkter [Internet]. Available from: <http://eur-lex.europa.eu/legal-content/EN/TXT/?uri=NIM:201367&qid=1495618570221>
 28. A Kormány 197/2014. (VIII. 1.) Korm. rendelele az elektromos és elektronikus berendezésekkel kapcsolatos hulladékgazdálkodási tevékenységekről [Internet]. Available from: <http://eur-lex.europa.eu/legal-content/EN/TXT/?uri=NIM:219902&qid=1495618570221>
 29. International Energy Agency, editor. Technology Roadmap. Hydrogen and Fuel Cells. [Internet]. 2015. Available from: <https://www.iea.org/publications/freepublications/publication/TechnologyRoadmapHydrogenandFuelCells.pdf>
 30. Lux Research, editor. The Great Compression: The Future of the Hydrogen Economy. 2012.
 31. European Commission, Directorate General for Research. Hyways: the European Hydrogen Roadmap : Contract SES6-502596. Luxembourg: EUR-OP; 2008.
 32. International Council on Clean Transportation Europe, editor. European vehicle market statistics. Pocketbook 2013 [Internet]. 2013. Available from: http://www.theicct.org/sites/default/files/publications/EU_vehiclemarket_pocketbook_2013_Web.pdf
 33. Marcel Weeda, Reinhold Wurster, Geert Schaap, Floris Mulder, Hein de Wilde, Ulrich Bünger, et al. Towards a comprehensive hydrogen infrastructure for fuel cell electric cars in view of EU GHG reduction targets. Hydrogen Infrastructure for Transport [Internet]. 2014 Sep 29; Available from: http://www.h2euro.org/wp-content/uploads/2014/10/HIT_SIP_Art-1_081014_final.pdf
 34. Directive 2000/53/EC of the European Parliament and of the Council of 18 September 2000 on end-of life vehicles [Internet]. Directive 2000/53/EC Sep 18, 2000. Available from: <http://eur-lex.europa.eu/legal-content/EN/TXT/?qid=1495625430015&uri=CELEX:32000L0053>
 35. Council Directive 70/156/EEC of 6 February 1970 on the approximation of the laws of the Member States relating to the type-approval of motor vehicles and their trailers.
 36. Commission Directive 92/62/EEC of 2 July 1992 adapting to technical progress Council Directive 70/311/EEC relating to steering equipment for motor vehicles and their trailers [Internet]. Jul 2, 1992. Available from: <http://eur-lex.europa.eu/legal-content/EN/TXT/?qid=1495628500586&uri=CELEX:31992L0062>
 37. European Commission. Report from the Commission to the EU parliament, the Council, the EU economic and social committee and the committee of the regions on the implementation of the Directive 2000/53/EC on ELVs from the periods 2008-2011 and 2011-2014 [Internet]. 2017.

- Available from: <https://ec.europa.eu/transparency/regdoc/rep/1/2017/EN/COM-2017-98-F1-EN-MAIN-PART-1.PDF>
38. Sakai S, Yoshida H, Hiratsuka J, Vandecasteele C, Kohlmeyer R, Rotter VS, et al. An international comparative study of end-of-life vehicle (ELV) recycling systems. *J Mater Cycles Waste Manag.* 2014 Feb;16(1):1–20.
 39. Real Decreto 20/2017, de 20 de enero, sobre los vehículos al final de su vida útil. [Internet]. Available from: <http://eur-lex.europa.eu/legal-content/EN/TXT/?uri=NIM:244577>
 40. Decreto Legislativo n° 209 del 24/6/2003 - Attuazione della Direttiva 2000/53 relativa ai veicoli fuori uso. GURI - Serie generale, n° 182 del 07/08/2003 p. 5 [Internet]. Available from: <http://eur-lex.europa.eu/legal-content/EN/TXT/?uri=NIM:113228>
 41. Uredba o taksi na obremenjevanje okolja zaradi nastajanja izrabljenih motornih vozil [Internet]. Available from: <http://eur-lex.europa.eu/legal-content/EN/TXT/?uri=NIM:30572>
 42. Gesetz über die Entsorgung von Altfahrzeugen (Altfahrzeug-Gesetz-Altfahrz.G) vom 21/06/2002 BGBl. n° 41 Teil I du 28/06/2002 p. 2199 [Internet]. Available from: <http://eur-lex.europa.eu/legal-content/EN/TXT/?uri=NIM:113222>
 43. Наредба за излезлите от употреба моторни превозни средства [Internet]. Available from: <http://eur-lex.europa.eu/legal-content/EN/TXT/?uri=NIM:135478>
 44. Regina Kohlmeyer. End-of-life vehicles recycling in Germany and recent developments [Internet]. International Workshop on 3R Strategy and ELV Recycling; 2012 Sep 19; Nagoya, Japan. Available from: https://www.umweltbundesamt.de/sites/default/files/medien/421/dokumente/abfall-ressourcen_produkterantwortung_alfahrzeuge_vortrag-int-workshop.pdf
 45. Matthias Buchert. Resource efficiency and resource-policy aspects of the electro-mobility system - Results. 11/11.
 46. I. Cavallotti, L. Pietrelli, D. Fontana, R. Nannicini. Il recupero di metalli preziosi dalle marmitte catalitiche. Proceedings Convegno Internazionale VARIREI (Valutazione, recupero e riciclaggio di rifiuti industriali). 2001 Jun 26;
 47. Directive 2006/66/EC of the European Parliament and of the Council of 6 September 2006 on batteries and accumulators and waste batteries and accumulators and repealing Directive 91/157/EEC.
 48. European Commission. Batteries & Accumulators [Internet]. 2016. Available from: <http://ec.europa.eu/environment/waste/batteries/index.htm>
 49. Directive 2008/12/EC of the European Parliament and of the Council of 11 March 2008 amending Directive 2006/66/EC on batteries and accumulators and waste batteries and accumulators, as regards the implementing powers conferred on the Commission [Internet]. Mar 19, 2008. Available from: <http://eur-lex.europa.eu/legal-content/EN/TXT/?qid=1495638244002&uri=CELEX:32008L0012>
 50. Directive 2008/103/EC of the European Parliament and of the Council of 19 November 2008 amending Directive 2006/66/EC on batteries and accumulators and waste batteries and accumulators as regards placing batteries and accumulators on the market.

51. Directive 2013/56/EU of the European Parliament and of the Council of 20 November 2013 amending Directive 2006/66/EC of the European Parliament and of the Council on batteries and accumulators and waste batteries and accumulators as regards the placing on the market of portable batteries and accumulators containing cadmium intended for use in cordless power tools, and of button cells with low mercury content, and repealing Commission Decision 2009/603/EC.
52. Real Decreto 106/2008, de 1 de febrero, sobre pilas y acumuladores y la gestión ambiental de sus residuos. [Internet]. Available from: <http://eur-lex.europa.eu/legal-content/EN/TXT/?uri=NIM:153775&qid=1495699739403>
53. Decreto Legislativo 20 novembre 2008, n. 188 Attuazione della direttiva 2006/66/CE concernente pile, accumulatori e relativi rifiuti e che abroga la direttiva 91/157/CEE [Internet]. Available from: <http://www.normattiva.it/uri-res/N2Ls?urn:nir:2008;188>
54. Uredba o ravnanju z baterijami in akumulatorji ter odpadnimi baterijami in akumulatorji [Internet]. Jan 15, 2010. Available from: <http://eur-lex.europa.eu/legal-content/EN/TXT/?uri=NIM:166242&qid=1495699739403>
55. Vyhláška č. 170/2010 Sb., o bateriích a akumulátorech a o změně vyhlášky č. 383/2001 Sb., o podrobnostech nakládání s odpady, ve znění pozdějších předpisů [Internet]. May 31, 2010. Available from: <http://eur-lex.europa.eu/legal-content/EN/TXT/?uri=NIM:169862&qid=1495699739403>
56. Verordnung des Bundesministers für Land- und Forstwirtschaft, Umwelt und Wasserwirtschaft über die Abfallvermeidung, Sammlung und Behandlung von Altbatterien und -akkumulatoren (Batterienverordnung) [Internet]. May 15, 2008. Available from: <http://eur-lex.europa.eu/legal-content/EN/TXT/?uri=NIM:155993&qid=1495699739403>
57. Μέτρα, όροι και πρόγραμμα για την εναλλακτική διαχείριση των αποβλήτων ηλεκτρικών σπηλών και συσσωρευτών σε συμμόρφωση με τις διατάξεις των οδηγιών, 2006/66/EK «σχετικά με τις ηλεκτρικές στήλες και τους συσσωρευτές και τα απόβλητα ηλεκτρικών σπηλών και συσσωρευτών και με την κατάργηση της οδηγίας 91/157/ΕΟΚ» και 2008/103/EK «για την τροποποίηση της οδηγίας 2006/66/EK σχετικά με τις ηλεκτρικές στήλες και τους συσσωρευτές και τα απόβλητα ηλεκτρικών σπηλών και συσσωρευτών, όσο αφορά την τοποθέτηση ηλεκτρικών σπηλών και συσσωρευτών στην αγορά», του Ευρωπαϊκού Κοινοβουλίου και του Συμβουλίου [Internet]. Oct 11, 2010. Available from: <http://eur-lex.europa.eu/legal-content/EN/TXT/?uri=NIM:172364&qid=1495699739403>
58. Kasutatud patareide ja akude käitlusõuded1 [Internet]. Jan 22, 2008. Available from: <http://eur-lex.europa.eu/legal-content/EN/TXT/?uri=NIM:153255&qid=1495699739403>
59. Wright EI, Rahimifard S, Clegg AJ. Impacts of environmental product legislation on solid oxide fuel cells. J Power Sources. 2009 May;190(2):362–71.
60. European Commission. Novel ways of substituting critical raw materials [Internet]. 2012. Available from: http://cordis.europa.eu/news/rcn/35357_en.html
61. CRM_InnoNet Project Web page [Internet]. Available from: <http://www.criticalrawmaterials.eu/>
62. Dan Carter. The Cost of Platinum in Fuel Cell Electric Vehicles. FuelCell Today [Internet]. 2013 Nov 6; Available from: http://www.fuelcelltoday.com/media/1895490/13-11-06_the_cost_of_platinum_in_fuel_cell_electric_vehicles.pdf

63. B. Rotmann, C. Lochbichler, B. Friedrich. Challenges in Titanium Recycling - Do We Need a New Specification for Secondary Alloys? Proceedings of EMC 2011 [Internet]. 2011; Available from: http://www.metallurgie.rwth-aachen.de/new/images/pages/publikationen/emc2011_rotmaen_id_9590.pdf
64. Environmental Protection Agency. Waste Classification. List of Waste & Determining if Waste is Hazardous or Non-hazardous [Internet]. 2015. Available from: https://epa.ie/pubs/reports/waste/stats/wasteclassification/EPA_Waste_Classification_2015_Web.pdf
65. European Commission, Directorate-General for Research and Innovation. Better regulations for innovation-driven investment at EU level: commission staff working document. [Internet]. Luxembourg: Publications Office; 2016 [cited 2017 May 24]. Available from: <http://bookshop.europa.eu/uri?target=EUB:NOTICE:KI0416030:EN:HTML>